

# ITS.

Implants  
trauma

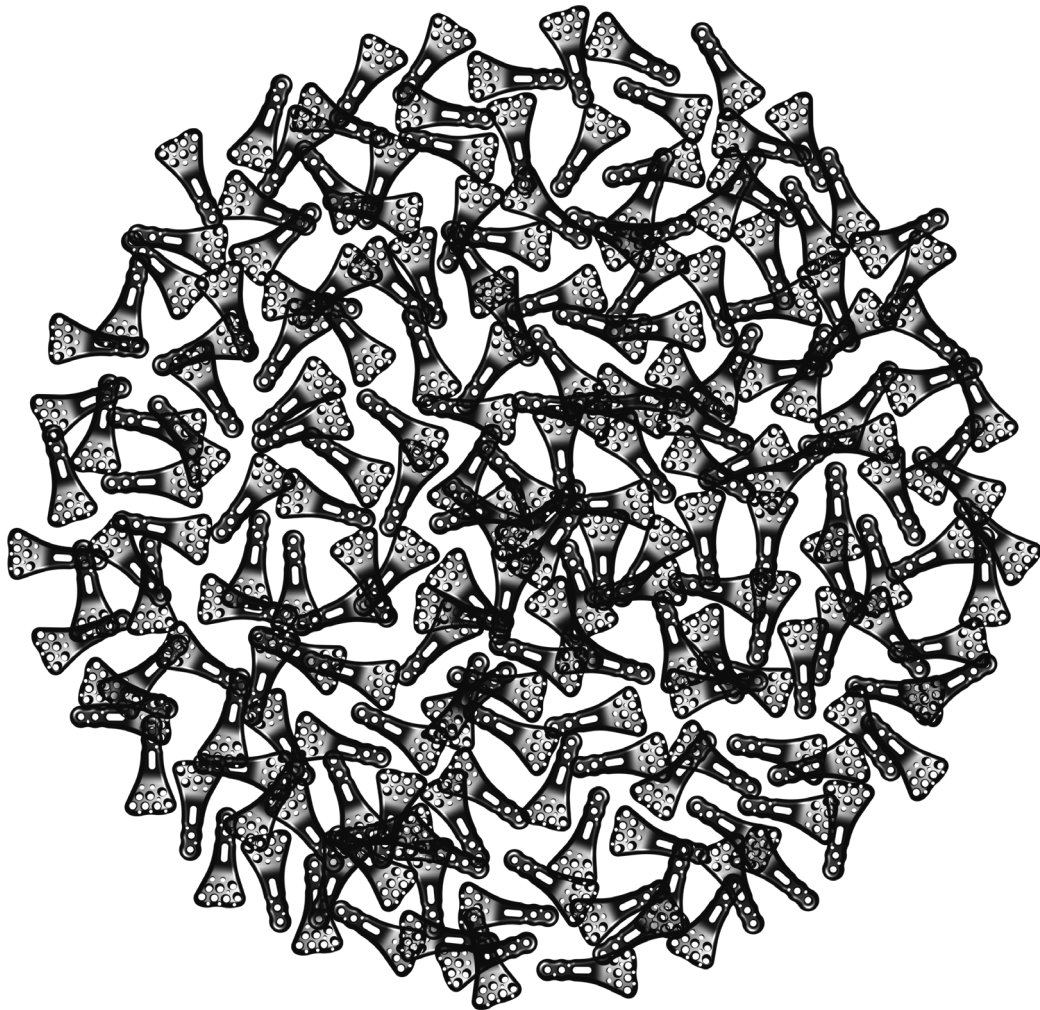

## PRL

PROlock Radius Locking Plate 2.0

All ITS plates are preformed anatomically as a matter of principle. If adjustment of the plate to the shape of the bone is required, this is possible by carefully bending gently in one direction once. Particular care is required when bending in the region of a plate hole, as deformation of the plate may lead to a failure of the locking mechanism. The plate must not be buckled or bent several times. This is particularly important in the case of titanium implants, to prevent material fatigue and subsequent failure. The method of bending is the conscious responsibility of the operating doctor; I.T.S. GmbH can accept no liability whatsoever for this.

## Contents

### **I. Introduction**

- P. 5 Preface
- P. 6 Screws
- P. 7 Properties
- P. 8 Advanced Properties
- P. 9 Drill Block
- P. 10 Indications & Contraindications
- P. 10 Time of operation

### **2. Surgical Technique**

- P. 12 Pre-operative patient preparation
- P. 13 Access
- P. 13 Implantation
- P. 21 Postoperative treatment
- P. 21 Explantation
- P. 21 Summary

### **3. Information**

- P. 23 Locking
- P. 23 Dotize®
- P. 24 Order list
- P. 26 Notes

# Introduction



## ○ Preface

The development of the PROlock Radius Locking Plate 2.0 is based on the excellent results of the previous ITS. Radius Plates.

The special feature of this implant is the free choice of screw placement. The user is able to set any desired screw in any hole (except oblong hole).

Minimization of flexor tendon irritation due to the anatomical plate design and rounded edges.

Precise and rapid screw placement of the distal plate holes with predefined angles using the radiolucent drill guide.



## ○ Screws

32271-XX Cortical Screw, D=2.7mm

61203-100 Spiral Drill, D=2.0mm, L=100mm, AO Connector

56095-70 Screwdriver, Torque, T9x70

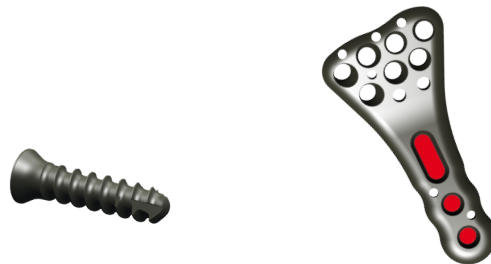

37304-XX Cortical Stabilization Screw, D=3.0mm, RH

61243-100 Spiral Drill, D=2.4mm, L=100mm, AO Connector

56095-70 Screwdriver, Torque, T9x70

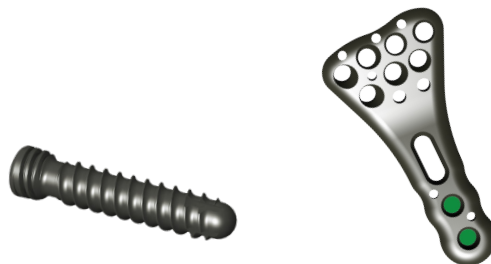

37303-XX Cancellous Stabilization Screw, D=3.0mm, RH

61203-100 Spiral Drill, D=2.0mm, L=100mm, AO Connector

56095-70 Screwdriver, Torque, T9x70

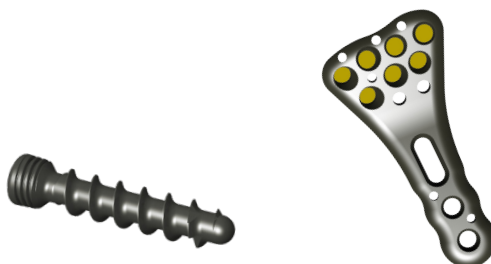

37241-XX Stabilization Screw, D=2.4mm, RH

61183-100 Spiral Drill, D=1.8mm, L=100mm, AO Connector

56095-70 Screwdriver, Torque, T9x70

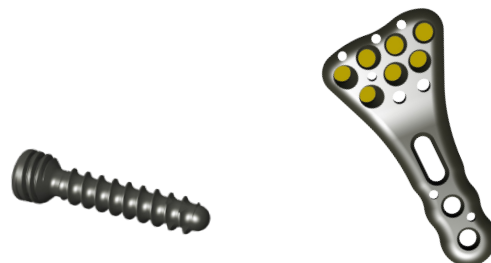

35164-150 Guide Wire, Steel, D=1.6mm,  
L=150mm, TR, w. thread



## ○ Properties

### Properties of the material:

- ◆ Plate material: Titanium
- ◆ Material of screws: TiAl6V4 ELI
- ◆ Easier removal of the implant after the fracture has healed
- ◆ Improved fatigue strength of the implant
- ◆ Reduced risk of cold welding
- ◆ Reduced risk of inflammation and allergy

### Properties of the implant:

- ◆ Multi-directional Locking
- ◆ Left/right version
- ◆ Minimization of flexor tendon irritation due to anatomical plate design
- ◆ K-Wire holes for preliminary plate fixation
- ◆ Oblong hole for optimal positioning and adjustment of radius length
- ◆ Plate lengths: 3, 5-hole
- ◆ Optional wide version: 3, 5-hole
- ◆ Optional long plates: 7, 9, 11-hole
- ◆ Optional drill block

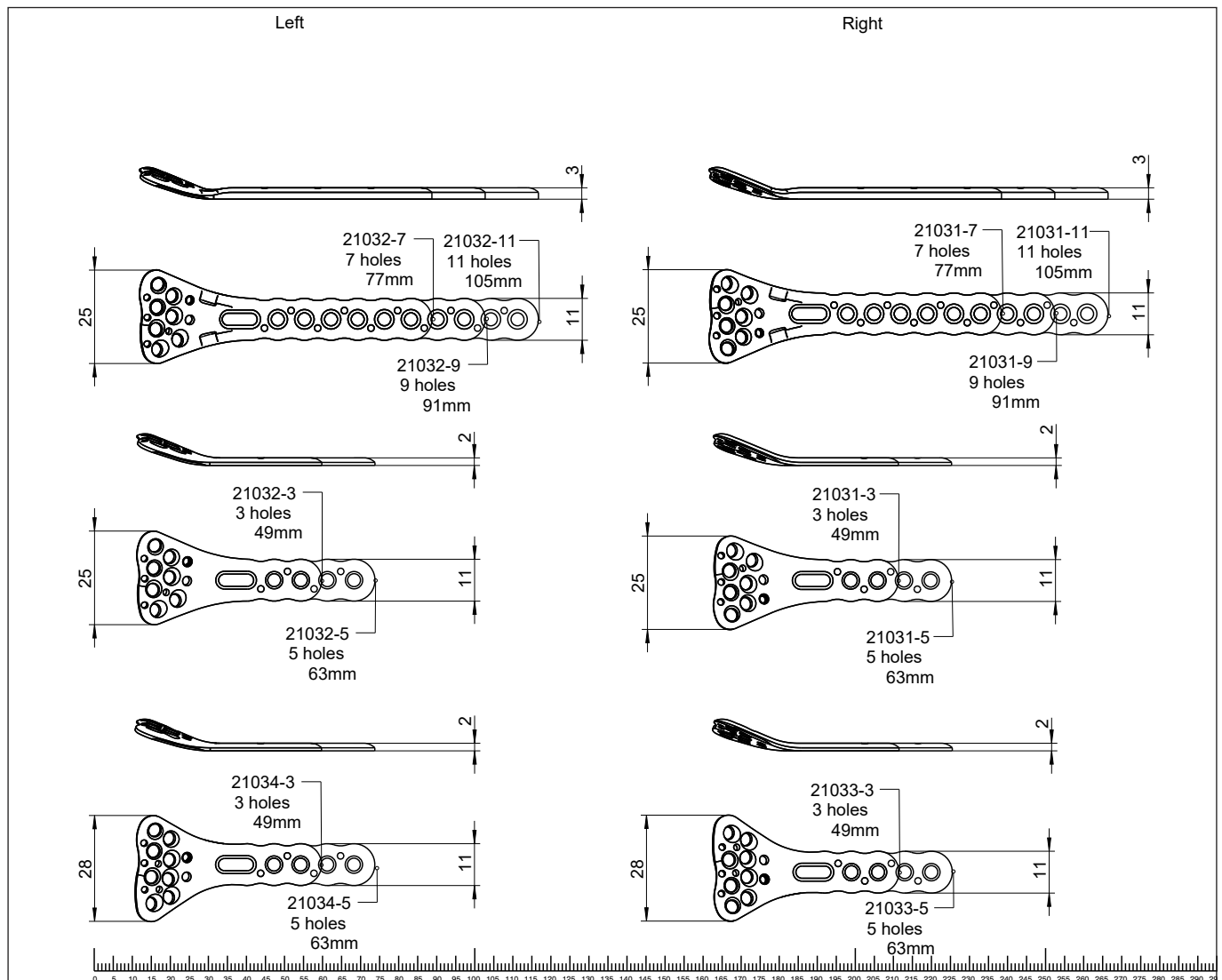

## ○ Advanced Properties

### PROlock 2.0:

- ◆ Predefined angles of the distal holes



Version left



Version right



Hole number	Direction proximal/distal	Direction ulnar/radial
1	distal 15°	radial 8°
2	proximal 5°	radial 8°
3	proximal 5°	radial 3°
4	proximal 5°	ulnar 3°
5	distal 5°	0°
6	distal 5°	radial 7°
7	distal 10°	radial 13°



## ○ Drill Block

### Properties:

- ◆ Precise and rapid screw placement with predefined angles
- ◆ Easy mounting and dismounting
- ◆ Radiolucent
- ◆ Allows for screw insertion through drill block
- ◆ Color coding for left and right version



### Assembling:

- ◆ Slide the drill block to the distal end till it audibly engages into the designated holes.
- ◆ Fix the drill block with the fixing screw (**62507**) for proper fixation.

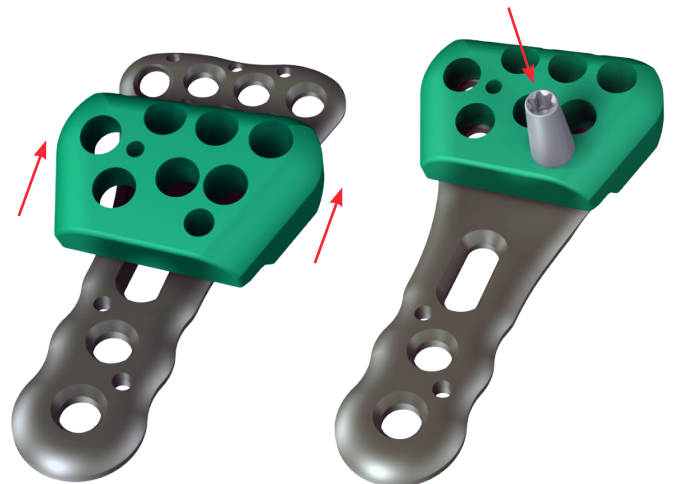

### Identification of screw length:

- ◆ PROlock II in single-hand design depth gauge (**59026**) can be pushed through the drill block to the plate, thus the thickness of the drill block does not need to be considered
- ◆ When using the standard design PROlock depth gauge (**59023**) subtract 6mm from the measured value

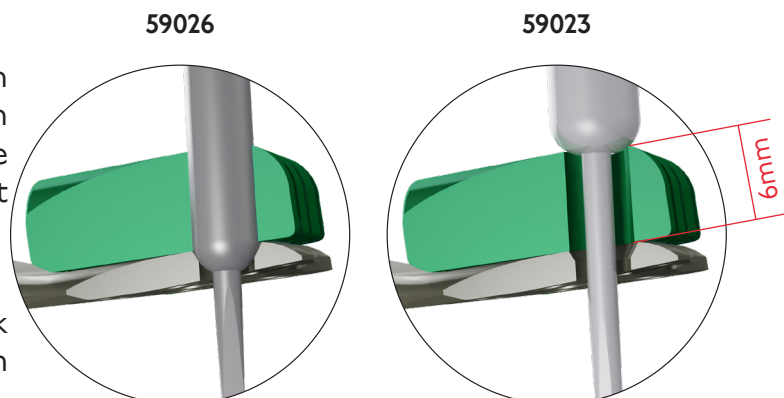

## ◦ Indications, Contraindications & Time of operation

### Indications:

- ◆ Complex intra- & extra-articular fractures of the distal radius with comminuted zone
- ◆ Corrective osteotomy of the distal radius

### Contraindications:

- ◆ Very advanced osteoporosis with soft bones
- ◆ Disintegration of the radius-joint surfaces to the extent that there is no support for screws
- ◆ Obesity
- ◆ Lack of patient compliance

### Time of operation:

- ◆ Acute, on the day of the accident
- ◆ After regression of the swelling
  
- ◆ In the case of additional questions concerning the wrist surface, a CT scan can be performed.

Inteded purpose

The plates, screw implants (non-locking and locking screws) and the instrumentation required for the Radius Plate System are used for temporary stabilisation of bone segments of the radius until bony consolidation is achieved.

# Surgical Technique

2.

## ○ Pre-operative patient preparation

- ◆ The patient is placed in the supine position with pneumatic partial deprivation of blood supply
- ◆ The hand is positioned on a radiolucent surgical hand table

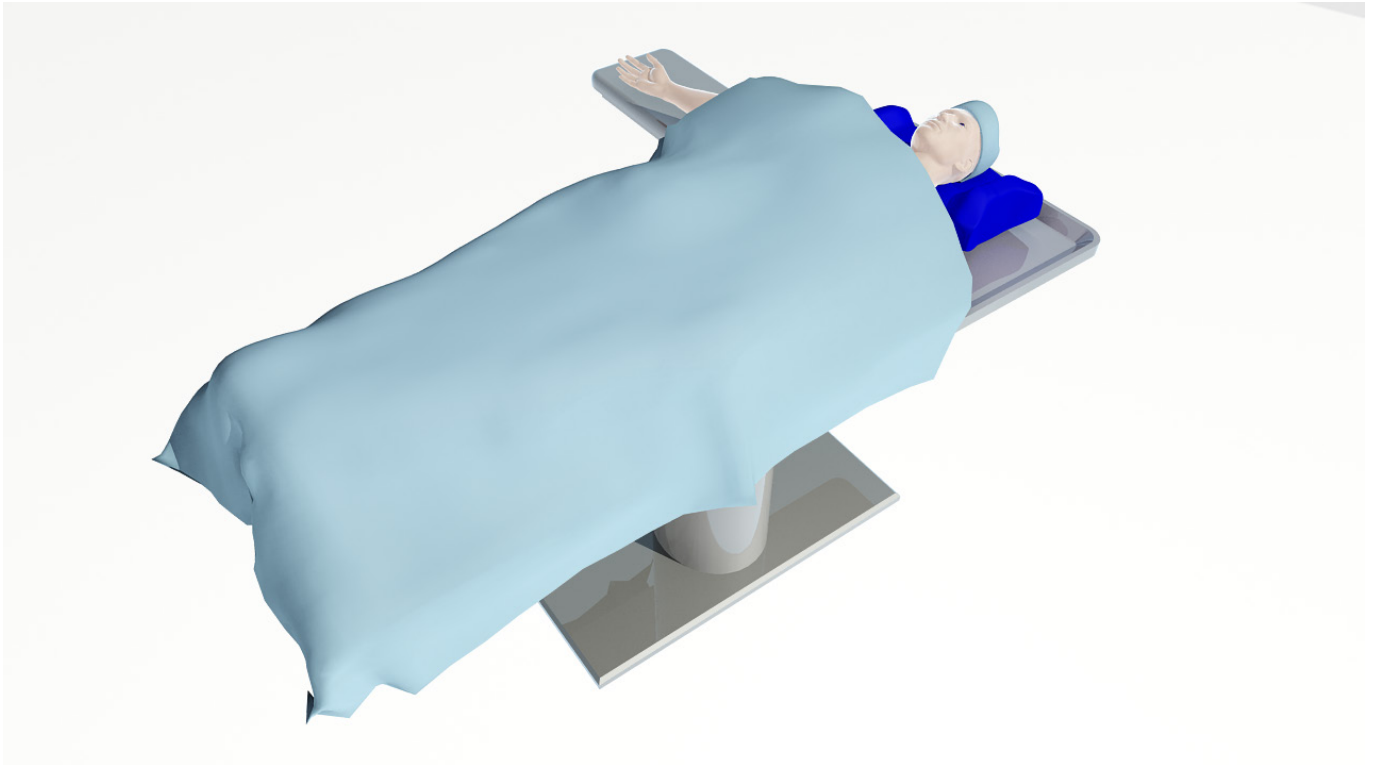

## ○ Access

The skin incision is performed volarly on the distal forearm above the tendon of the flexor carpi radialis and reaching to the crease of the wrist (FCR-approach).

Split the deep fascia of the forearm. Release the pronator quadratus muscle from the distal radius beginning at the radial edge.

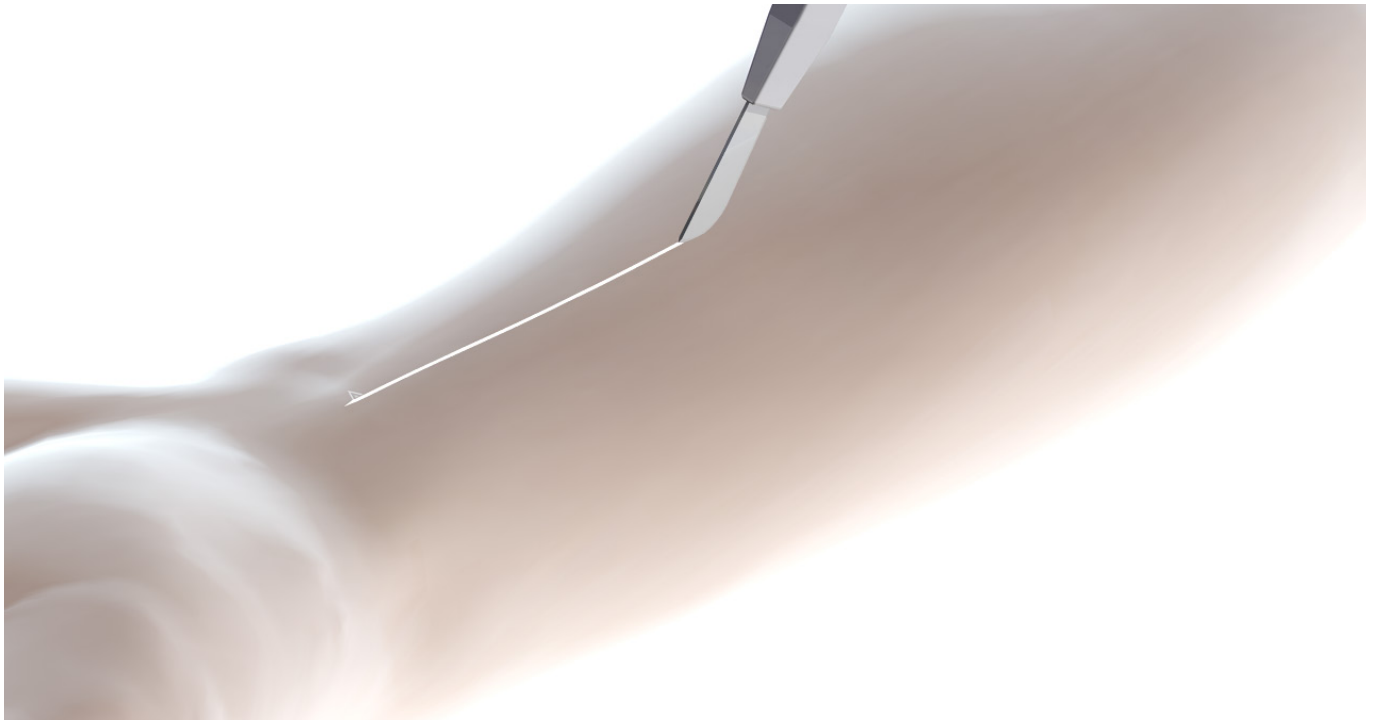

## ○ Implantation

Suspending the thumb with a counterpoise, the fracture is loosened and the length restored.

The individual fragments are reduced with the appropriate instrumentation, and, if necessary, the comminuted zones are filled with bone substitute to achieve a provisional reduction in position and length.

Possible temporary fixation of individual fragments using a guide wire, steel, D=1.6mm, L=150mm, TR w. Thrd. **(35164-150)** - check reduction under fluoroscopy.

After anatomical reduction is achieved, the implant is chosen and, if required, its contour can be modified.



First, fill the oblong hole with a D=2.7mm cortical screw **(32271-XX)** (suitable drills see page 6). Check the reduction and position of the plate under fluoroscopy.



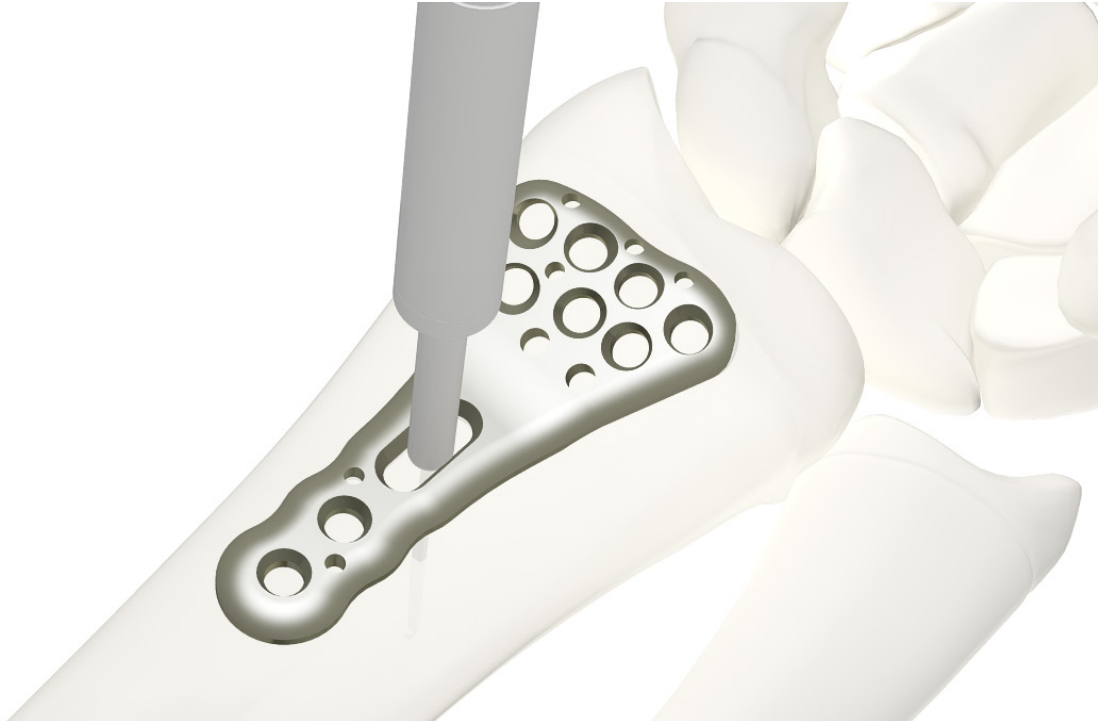

Due to the oblong hole it is possible to adjust the plate position either distal or proximal.



For temporary fixation of the fragments there are 3 distal K-wire holes.





Next fill the shaft holes with either D=3.0mm cortical stabilization screws (**37304-XX**) or with D=2.7mm cortical screws (**32271-XX**) (suitable drills see page 6).

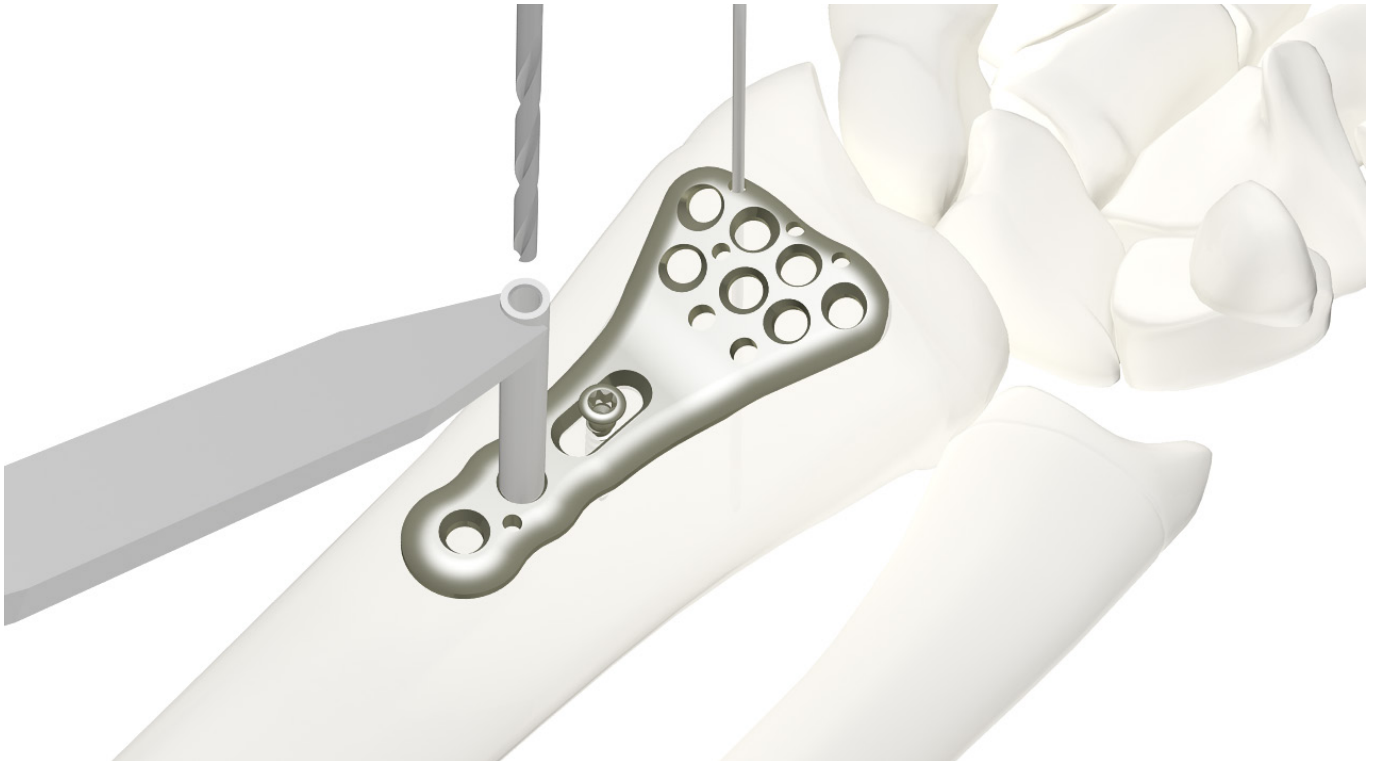

After re-checking the reduction 4 or more D=2.4mm stabilization screws (**3724I-XX**) or D=3.0mm cancellous stabilization screws (**37303-XX**) should be used for the relevant fragments (suitable drills see page 6). Pay attention that the distal locking screws are placed as closely to the wrist surface as possible in order to take advantage of the hard subchondral bone.

Two rows of screws are recommended to provide optimal support to the articular surface especially if only the D=2.4mm stabilization screw is used. Final check under fluoroscopy.







## ○ Postoperative treatment

- ◆ Dorsal splint (1-2 weeks)
- ◆ Physical therapy

## ○ Explantation

Removal is possible, if desired by the patient.  
Implant removal 6 months after surgery.

The problem of cold welding was resolved by using a special surface treatment (for further information see page 23).

## ○ Summary

The ITS. locking Radius Plate has proven itself in extension fractures of the distal radius with a dorsal comminution zone.

Using this technology, an anatomic reduction was achieved and maintained until healing occurred.

Due to the low immobilization time of 2 weeks, rapid rehabilitation and early movement of the wrist could be achieved.

Development of the PROlock Radius Locking Plate 2.0 is based on the excellent results of the ITS. Radius Plates. A series of improvements have simplified the procedure.

Information

3.

## ○ Locking

### Locking works because:

- ◆ Screw material (TiALV) is slightly harder than plate material (Titanium Grade 2)
- ◆ Screw head **forms** thread into the plate (no cutting)

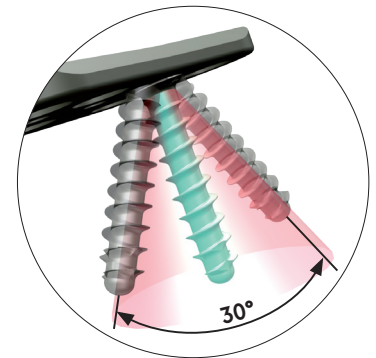

### Benefits:

- ◆  $\pm 15^\circ$  and Locking
- ◆ No pre threading
- ◆ No cold welding
- ◆ No debris
- ◆ You can re-set the screw up to 3 times

## ○ Dotize<sup>®</sup>

### Chemical process - anodization in a strong alkaline solution\*

#### Type III anodization

- ◆ Layer thickness 60-200nm
- + Different colors
- Implant surface remains sensitive to:  
Chipping  
Peeling  
Discoloration

#### Dotize

#### Type II anodization

- ◆ Layer thickness 2000-10 000nm
- + Film becomes an interstitial part of the titanium
- No visible cosmetic effect

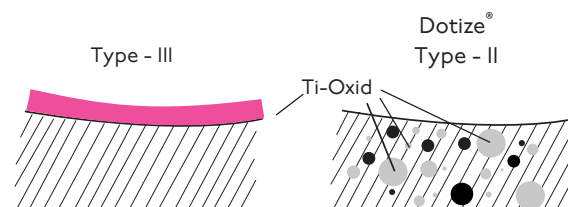

### Anodization Type II leads to following benefits\*

- ◆ Oxygen and silicon absorbing conversion layer
- ◆ Decrease in protein adsorption
- ◆ Closing of micro pores and micro cracks
- ◆ Reduced risk of inflammation and allergy
- ◆ Hardened titanium surface
- ◆ Reduced tendency of cold welding of titanium implants
- ◆ Increased fatigue resistance of implants
- ◆ Improved wear and friction characteristics

## ○ Order list

Radius Plate PROlock II, 3-hole, Right	21031-3	
Radius Plate PROlock II, 3-hole, Left	21032-3	
Radius Plate PROlock II, 5-hole, Right	21031-5	
Radius Plate PROlock II, 5-hole, Left	21032-5	

### Special Lengths (on request)

Radius Plate PROlock II, 7-hole, Right	21031-7	
Radius Plate PROlock II, 7-hole, Left	21032-7	
Radius Plate PROlock II, 9-hole, Right	21031-9	
Radius Plate PROlock II, 9-hole, Left	21032-9	
Radius Plate PROlock II, 11-hole, Right	21031-11	
Radius Plate PROlock II, 11-hole, Left	21032-11	
Radius Plate PROlock II, 3-hole, Right, Wide	21033-3	
Radius Plate PROlock II, 3-hole, Left, Wide	21034-3	
Radius Plate PROlock II, 5-hole, Right, Wide	21033-5	
Radius Plate PROlock II, 5-hole, Left, Wide	21034-5	









Cancellous Stabilization Screw, D=3.0mm, L=14mm, RH	37303-14	
Cancellous Stabilization Screw, D=3.0mm, L=16mm, RH	37303-16	
Cancellous Stabilization Screw, D=3.0mm, L=18mm, RH	37303-18	
Cancellous Stabilization Screw, D=3.0mm, L=20mm, RH	37303-20	
Cancellous Stabilization Screw, D=3.0mm, L=22mm, RH	37303-22	
Cancellous Stabilization Screw, D=3.0mm, L=24mm, RH	37303-24	
Cancellous Stabilization Screw, D=3.0mm, L=26mm, RH	37303-26	
Cancellous Stabilization Screw, D=3.0mm, L=28mm, RH	37303-28	
Cancellous Stabilization Screw, D=3.0mm, L=30mm, RH	37303-30	

Stabilization Screw, D=2.4mm, L=14mm, RH	37241-14	
Stabilization Screw, D=2.4mm, L=16mm, RH	37241-16	
Stabilization Screw, D=2.4mm, L=18mm, RH	37241-18	
Stabilization Screw, D=2.4mm, L=20mm, RH	37241-20	
Stabilization Screw, D=2.4mm, L=22mm, RH	37241-22	
Stabilization Screw, D=2.4mm, L=24mm, RH	37241-24	
Stabilization Screw, D=2.4mm, L=26mm, RH	37241-26	
Stabilization Screw, D=2.4mm, L=28mm, RH	37241-28	
Stabilization Screw, D=2.4mm, L=30mm, RH	37241-30	

Cortical Stabilization Screw, D=3.0mm, L=10mm, RH	37304-10	
Cortical Stabilization Screw, D=3.0mm, L=12mm, RH	37304-12	
Cortical Stabilization Screw, D=3.0mm, L=14mm, RH	37304-14	
Cortical Stabilization Screw, D=3.0mm, L=16mm, RH	37304-16	
Cortical Stabilization Screw, D=3.0mm, L=18mm, RH	37304-18	
Cortical Stabilization Screw, D=3.0mm, L=20mm, RH	37304-20	
Cortical Stabilization Screw, D=3.0mm, L=22mm, RH	37304-22	
Cortical Stabilization Screw, D=3.0mm, L=24mm, RH	37304-24	

Cortical Screw, D=2.7mm, L=10mm	32271-10	
Cortical Screw, D=2.7mm, L=12mm	32271-12	
Cortical Screw, D=2.7mm, L=14mm	32271-14	
Cortical Screw, D=2.7mm, L=16mm	32271-16	
Cortical Screw, D=2.7mm, L=18mm	32271-18	
Cortical Screw, D=2.7mm, L=20mm	32271-20	
Cortical Screw, D=2.7mm, L=22mm	32271-22	
Cortical Screw, D=2.7mm, L=24mm	32271-24	

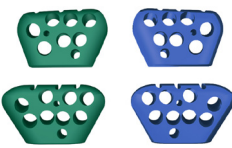

Screwdriver, Torque, T9x70	56095-70	
Depth Gauge, PROlock II	59026	
Spiral Drill, D=1.8mm, L=100mm, AO Connector	61183-100	
Spiral Drill, D=2.0mm, L=100mm, AO Connector	61203-100	
Spiral Drill, D=2.4mm, L=100mm, AO Connector	61243-100	
Drill Guide, D=2.0/2.4mm	62215	
Guide Wire, Steel, D=1.6mm, L=150mm, TR, w. thread	35164-150	
Sterilization Tray, Radius Plate PROlock II	50261	
<b>Optional (on request)</b>		
Drill Block PROlock II, Left	62500	
Drill Block PROlock II, Right	62501	
Drill Block PROlock II, Left, Wide	62502	
Drill Block PROlock II, Right, Wide	62503	
Fixing Screw, Drill Block, PROlock II	62507	
Depth Gauge, PROlock	59023	

For detailed cleaning and sterilization instructions, please refer to package insert.

## Tray









**ITS. GmbH**  
Autal 28, 8301 Lassnitzhöhe, Austria  
Tel.: +43 (0) 316 / 211 21 0  
Fax: +43 (0) 316 / 211 21 20  
office@its-implant.com  
www.its-implant.com



Order No. PRL2-OP-0723-EN  
Edition: July/2023

© ITS. GmbH Graz/Austria 2023.  
Subject to technical alterations, errors and misprints excepted.